

medifa®



made in Germany

# MUS4000 IV

UNTERSUCHUNGSSTUHL - SYSTEME



EXAMINATION CHAIR SYSTEMS



# POLSTERUNG

## UPHOLSTERY

Die Polsterung der Untersuchungsstühle besteht aus einer mit Schaumstoff verklebten Trägerplatte. Diese ist nahtlos mit einem strapazierfähigen Kunstleder bezogen. Es steht ein reichhaltiges Spektrum an modernen Polsterfarben zur Auswahl.

Die ergonomische Ausformung der Polster stabilisiert die Positionierung des Patienten.

Gerundete Polsterkanten und abgerundete, verstärkte Polsterecken vervollständigen das edle und funktionelle Design der Stühle.

*The upholstery of the examination chairs consists of a foam padding glued on a synthetic material board. It is seamlessly covered with a tear-proof. Various modern colours are available.*

*The ergonomic design of upholstery stabilizes patient's positioning on the chair.*

*The rounded edges and angles of the upholstery make up the noble and functional design of the chairs.*



### Gestellfarbe / frame colour:





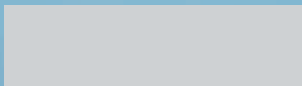



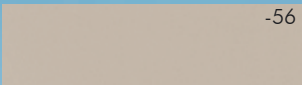

Kunststoffbeschichtung:  
Powder coating:  
Weiß (RAL 9010)  
White (RAL 9010)

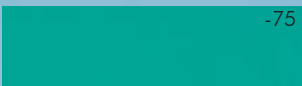

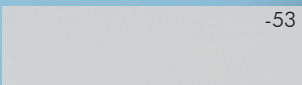
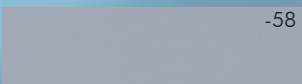
Kunststoffbeschichtung:  
Powder coating:  
Weißaluminium (RAL 9006)  
White-aluminium (RAL 9006)

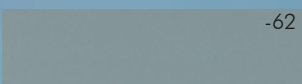
### Polsterfarben / upholstery colours:

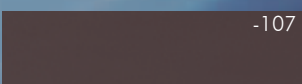
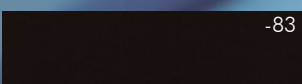
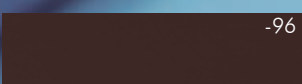
	-50	Weiss White
	-56	Beige Beige
	-67	Limonade Lemonade
	-75	Agave Agave
	-73	Apricot Apricot
	-53	Perle Pearl
	-58	Stone Stone
	-55	Dolphin Dolphin
	-62	Bleu Light blue
	-74	Atoll Atoll
	-80	Royal Royal
	-107	Graphitgrau Graphite grey
	-83	Schwarz Black
	-96	Schwarz, elekt. leitend Black, electrically conducting

# FUNKTIONAL

## FUNCTIONAL



- Höhenverstellung von 550 bis 900 mm  
*Height adjustment from 550 up to 900 mm*

- Elektromotorische Becken-  
hochlagerung bis + 25°  
*Powered adjustment of pelvis  
section up to + 25°*



- Elektromotorische Rückenlehn-  
verstellung von -15° bis + 50°  
*Powered adjustment of back  
section from -15° up to + 50°*



# PERFEKTION & ERGONOMIE

## PERFECTION & ERGONOMICS

Die Untersuchungsstühle der Serie MUS 4000 IV zeichnen sich durch eine kompakte und praxisorientierte Bauweise aus. Der variable Einsatz der Stühle wird durch eine bedienerfreundliche Handhabung gewährleistet. Durch eine bequeme Polsterung besteht ein hoher Liegekomfort für den Patienten. Die elektrischen Verstellmöglichkeiten erfolgen mittels leicht bedienbaren Schaltern. Reichhaltiges Zubehör eröffnet ein großes Spektrum an Einsatzmöglichkeiten.

*The examination chair model MUS 4000 IV is characterized by a compact and practice-oriented design and construction. Variable applications realisable through user friendly handling. A high level of convenience is ensured due to comfortable upholstery. Powered adjustments are carried out by easy operated switches. Wide range of accessories offer a wide spectrum of possible application.*





# VARIANTEN GYNÄKOLOGIE

## VERSION GYNAECOLOGY

### 11400408

Elektrisch verstellbarer Untersuchungs- und Behandlungsstuhl mit Beckenhochlagerung und Rückenlehnenverstellung.  
Gestellfarbe: weiß (RAL9010)

*Examination chair with powered adjustment of pelvis section and back section.*

*Frame colour: white (RAL9010)*

Alternativ:

*Alternative:*

### 12400408

Wie 11400408, jedoch Gestellfarbe weißaluminium (RAL9006)

*As 11400408, however with frame colour white-aluminium (RAL9006)*

Abgebildetes Zubehör:

*Shown accessories:*

### 40017

Arzt-Fußstütze

*Foot rest for doctors*

### 81725

Fußplatten (Paar)

*Foot rests (pair)*



**11400420**

Elektrisch verstellbarer Untersuchungs- und Behandlungsstuhl mit Höhenverstellung, Beckenhochlagerung und Rückenlehnenverstellung.

Gestellfarbe: weiß (RAL9010)

*Examination chair with powered height adjustment, adjustment of pelvis section and back section.  
Frame colour: white (RAL9010)*

Alternativ:

*Alternative:*

**12400420**

Wie 11400420, jedoch Gestellfarbe weißaluminium (RAL9006)

*As 11400420, however with frame colour white-aluminium (RAL9006)*

Abgebildetes Zubehör:

*Shown accessories:*

**40017**

Arzt-Fußstütze

*Foot rest for doctors*

**81725**

Fußplatten (Paar)

*Foot rests (pair)*



### 12400450

Elektrisch verstellbarer Untersuchungs- und Behandlungsstuhl mit Höhenverstellung, Beckenhochlagerung, Rückenlehnenverstellung, Handschalter und Abrufmöglichkeit von jeweils 3 Memorypositionen für 4 Benutzer  
Gestellfarbe: weißaluminium (RAL9006)

*Examination chair with powered height adjustment, adjustment of pelvis and back section, hand switch and memory function with three memory programmable positions for four operators.  
Frame colour: white-aluminium (RAL9006)*

Alternativ:  
Alternative:

### 11400450

wie 12400450, jedoch Gestellfarbe weiß (RAL9010)

*as 12400450, however with frame colour white (RAL9010)*

Abgebildetes Zubehör:

*Shown accessories:*

### 40017

Arzt-Fußstütze

*Foot rest for doctors*

### 81716

Beinhalter nach Goepel Comfort (Paar)

*Foot rests according to Goepel Comfort (pair)*





# VARIANTEN UROLOGIE

## VERSION UROLOGY

### 11400420

Elektrisch verstellbarer Untersuchungs- und Behandlungsstuhl mit Höhenverstellung, Beckenhochlagerung und Rückenlehnenverstellung.

Gestellfarbe: weiß (RAL9010)

*Examination chair with powered height adjustment, adjustment of pelvis and back section*  
Frame colour: white (RAL9010)

Alternativ:

Alternative:

### 12400420

Wie 11400420, jedoch Gestellfarbe weißaluminium (RAL9006)

*As 11400420, however with frame colour white-aluminium (RAL9006)*

Abgebildetes Zubehör:

*Shown accessories:*

### 1128530 / 28531

Haltegriffe, weiß (RAL9010) mit Kunstlederbezug (Paar)

*Hand grips, white (RAL9010) covered with artificial leather (pair)*

### 85220 / 85221

Führungsschienen für Rückenlehne und Beckenteil

*Side rails for back and pelvis section*

### 81500

Haltekloben, drehbar aus ChrNiSt (Paar)

*Clamps, rotatable, made of s/s (pair)*

### 81700

Beinhalter nach Goepel Classic (Paar)

*Leg holders according to Goepel Classic (pair)*

### 91705

Kreiselspülung aus ChrNiSt

*Collecting basin with rinsing device, made of s/s*



**12400450**

Elektrisch verstellbarer Untersuchungs- und Behandlungsstuhl mit Höhenverstellung, Beckenhochlagerung, Rückenlehnenverstellung, Handschalter und Abrufmöglichkeit von jeweils 3 Memorypositionen für 4 Benutzer

Gestellfarbe:  
weißaluminium (RAL9006)

*Examination chair with powered height adjustment, adjustment of pelvis and back section, hand switch and memory functions with three programmable memory positions for four operators.*

*Frame colour:  
white-aluminium (RAL9006)*

Alternativ:

*Alternative:*

**11400450**

Wie 12400450, jedoch Gestellfarbe weiß (RAL9010)

*As 12400450, however with frame colour white (RAL9010)*

Abgebildetes Zubehör:

*Shown accessories:*

**1228530 / 28531**

Haltegriffe, weißaluminium (RAL9006) mit Kunstlederbezug

*Hand grips, white aluminium (RAL9006) covered with artificial leather*

**85220 / 85221**

Führungsschienen für Rückenlehne und Beckenteil

*Side rails for back and pelvis section*

**81500**

Haltekloben, drehbar aus ChrNiSt (Paar)

*Clamps, rotatable, made of s/s (pair)*

**81705**

Beinhalter nach Goepel Comfort (Paar)

*Leg holders according to Goepel Comfort (pair)*

**91705**

Kreiselspülung aus ChrNiSt

*Collecting basin with rinsing device made of s/s*



# ZUBEHÖR

## ACCESSORIES

Nr. 1  
**85220**

Seitliche Führungsschienen für die Rückenlehne zur Anbringung von Zubehör (Paar) L= 600 mm

*Back section side rails for accessory attachment (pair), l= 600 mm*

**85221**

Seitliche Führungsschienen für das Beckenteil zur Anbringung von Zubehör (Paar) L= 320 mm

*Pelvis section side rails for accessory attachment (pair), l= 320 mm*

Nr. 2  
**81500**

Halteklappen, drehbar aus ChrNiSt., (Paar)

*Clamps, rotatable, made of s/s (pair)*

Nr. 3  
**81725**

Fußplatte (Paar)

*Foot rest (pair)*

Nr. 4  
**81716**

Beinhalter nach Goepel Comfort (Paar)

*Leg holders according to Goepel Comfort (pair)*

Nr. 5  
**81700**

Beinhalter nach Goepel Classic (Paar)

*Leg holders according to Goepel Classic (pair)*

**81710**

Aufpreis für Bezug der Beinschalen mit Kunstleder in Polsterfarbe (Paar)

*Additional charge for covered artificial leather (pair)*

Nr. 6  
**81705**

Beinhalter nach Goepel Comfort zur Befestigung an der Führungsschiene (Paar)

*Leg holder according to Goepel Comfort for side rail attachment (pair)*



# ZUBEHÖR

## ACCESSORIES



Nr. 7  
**1128530 / 1228530**

Haltegriffe in weiß  
RAL 9010 (Paar) / weiß-  
aluminium RAL9006 (Paar)  
*Hand grips white RAL 9010  
(pair) / white-aluminium  
RAL9006 (pair)*

**28531**

Aufpreis für Bezug der Handgriffe  
mit Kunstleder in Polsterfarbe  
(Paar)

*Additional charge for artificial  
leather cover of handgrips in  
colour of upholstery (pair)*

Nr. 8

**61210**

Armauflage, verstellbar, Polster  
Integralschaum, elektrisch leit-  
fähig, einschl. Befestigung L=  
300 mm

*Arm rest, multiple adjustments,  
integral foam, electrically conduc-  
ting, incl. fastening  
l= 300 mm*

Nr. 9

**400075**

Beinplatte, einschiebbar, Liege-  
fläche bis 1590 mm (nicht in  
Verbindung mit 91705 Kreisel-  
spülung und 91607 Nirostasche-  
le mit Abfluss und Schlauch)

*Leg plate, insertable, lying  
surface up to 1590 mm (not in  
combination with 91705 rinsing  
facility and 91607 stainless steel  
disk, with outlet and tube)*

Nr. 10

**400065**

Beinplatte, einsteckbar, Liegenflä-  
che bis 1810 mm

*Leg plate, detachable, lying  
surface up to 1810 mm*

Nr. 11

**11/1282345R\_System /  
11/1282345L\_System**

Kolposkophalterung für Systeme  
Olympus, Kaps, Zeiss, Leisegang  
rechtsseitig (82345R) oder links-  
seitig (82345L)

*Colposcope holder for systems  
Olympus, Kaps, Zeiss, Leisegang  
right sided (82345R) or left sided  
(82345L)*

Nr. 12

**40017**

Fußstütze aus ChrNiSt.

*Foot rest made of s/s*

Nr. 13

**40675**

Steckdose am Sockel, max. 2

Stück

*Socket at the base, max. 2 pieces*

**40676**

Potentialausgleichsbuchse am  
Sockel

*Potential equalisation socket at  
base*

Nr. 14

**91705**

Kreiselspülung (ø 320mm) aus  
ChrNiSt. mit Zu- und Ablauf,  
Wasserzulauf elektromagnetisch  
über Fußschalter zu bedienen

*Collecting basin (ø 320mm)  
made of s/s with rinsing device,  
inflow electromagnetically con-  
trolled via foot switch*

Nr. 15

**91607**

Nirostaschale, mit Abfluß und  
Schlauch

*Stainless steel disk, with outlet  
and tube*

**91608**

Eimer aus ChrNiSt. 18/8, Volu-  
men 12 Liter, einschl. Deckel

*Bucket made of 18/8 s/s,  
volume 12 litres, incl. lid with  
tube-inlet*

Nr. 16

**40045**

Handschalter zur Steuerung der  
Funktionen Höhenverstellung,  
Beckenteilverstellung und Rü-  
ckenlehnenverstellung  
(nur für die Modelle  
11400420/12400420)

*Hand switch for control of  
height adjustment, pelvis  
section adjustment and back  
section adjustment (only for items  
11400420/12400420)*



# TECHNIK & MEHR

## TECHNIQUE & MORE

### Modell 11400408

Grundausstattung:

- Gestellfarbe: Weiß (RAL 9010)
- Feste Höhe von 700mm
- Elektr. Beckenteilverstellung: 0°/ +25°
- Elektr. Rückenteilverstellung: -15°/ +50°
- Elektr. Auslösungen über leichtbedienbare Fußschalter
- Kopfteil längsverstellbar
- Integrierte Nackenstütze
- Papierrollenhalter im Rückenteil
- Ergonomische Polsterform
- Polsterstärke: 50 mm
- Bodenausgleichsschrauben
- Aufnahmevorrichtung für einsteckbare Beinplatte
- Aufnahmevorrichtung für seitliche Führungsschienen
- Auffangschale schwenkbar
- max. Patientengewicht: 180 kg
- Stellfläche: 950 x 560 mm
- Netzanschluss: 110/230 V / 50-60Hz

Basic features:

- *Frame colour: white (RAL 9010)*
- *Fixed height of 700 mm*
- *Powered adjustment of pelvis section: 0°/ +25°*
- *Powered adjustment of back section: -15°/ +50°*
- *Powered activation through comfortable foot switch*
- *Height adjustable head section*
- *Integrated neck support*
- *Paper roll holder behind the back section*
- *Upholstery with ergonomic form*
- *Upholstery thickness: 50 mm*
- *Floor leveling screws*
- *Mounting device for insertable leg plate*
- *Mounting device for side rail attachment*
- *Swiveling basin*
- *Loading capacity: 180 kg*
- *Floor space required: 950 x 560 mm*
- *Power supply: 110/230 V / 50-60Hz*

### Modell 12400408

Grundausstattung:

Wie 11400408, jedoch Gestellfarbe: Weißaluminium (RAL 9006)

Basic features:

Same as 11400408, however base frame: white-aluminium (RAL9006)

### Modell 11400420

Grundausstattung:

Wie 11400408, jedoch zusätzlich höhenverstellbar von 550 mm bis 900 mm

Basic features:

Same as 11400408, however with height adjustment from 550 mm to 900 mm

### Modell 12400420

Grundausstattung:

Wie 11400420, jedoch Gestellfarbe: Weißaluminium (RAL 9006)

Basic features:

Same as 11400420, however base frame: white-aluminium (RAL9006)

### Modell 11400450

Grundausstattung:

Wie 11400420, jedoch zusätzliche Bedienmöglichkeit über Handschalter (Halterung inklusive), Abrufmöglichkeit von jeweils 3 Memorypositionen für 4 Benutzer.

Basic features:

Same as 11400420, however with operating possibility through hand control (holder included), memory function with three programmable memory positions for four operators.









### Modell 12400450

Grundausstattung:

Wie 11400450, jedoch Gestellfarbe: Weißaluminium (RAL 9006)

Basic features:

Same as 11400450, however base frame: white-aluminium (RAL9006)

					
		Verstellbereich Range	11/12 400408 *	11/12 400420	11/12 400450
	Höhenverstellung Height adjustment	550 - 900 mm		○	○
	Beckenhochlagerung Adjustment of pelvis section	+25 °	○	○	○
	Rückenlehnenverstellung Adjustment of back section	-15° / +50°	○	○	○
	MEMORY (12 Positionen) Memory (12 positions)				○
	Handschalter Hand switch			◆	○

◆ optional  
optional

○ elektrisch  
powered

\* feste Höhe 700 mm  
fixed height 700 mm

# 180 KG

Für 180 kg Patientengewicht!  
Loading capacity up to 180 kg!

# GRUNDFUNKTIONEN

## BASIC FEATURES

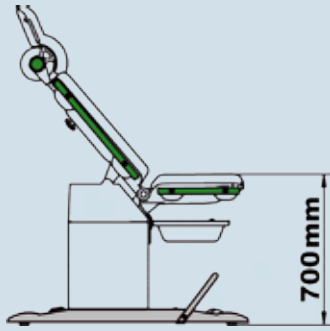

11400408  
12400408

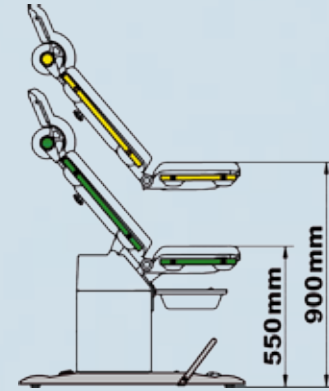

11400420 / 11400450  
12400420 / 12400450

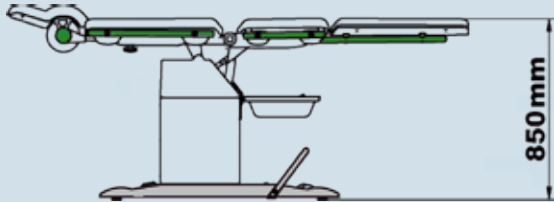

11400408  
12400408

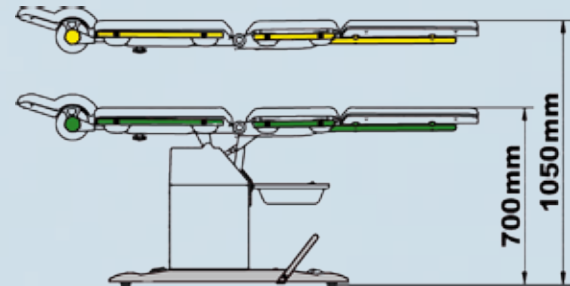

11400420 / 11400450  
12400420 / 12400450

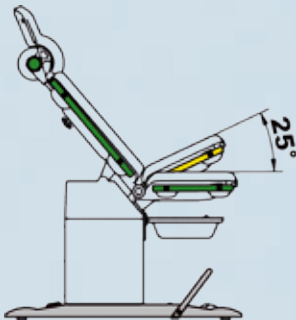

11400408 / 11400420 / 11400450  
12400408 / 12400420 / 12400450

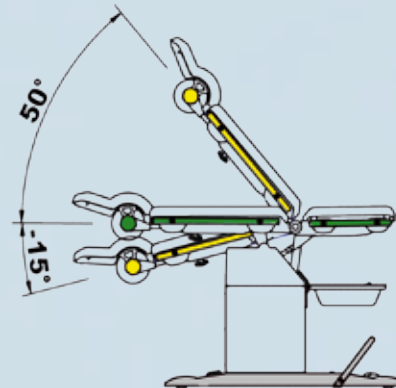

11400408 / 11400420 / 11400450  
12400408 / 12400420 / 12400450



# GRUNDRISS

## GROUNDPLAN

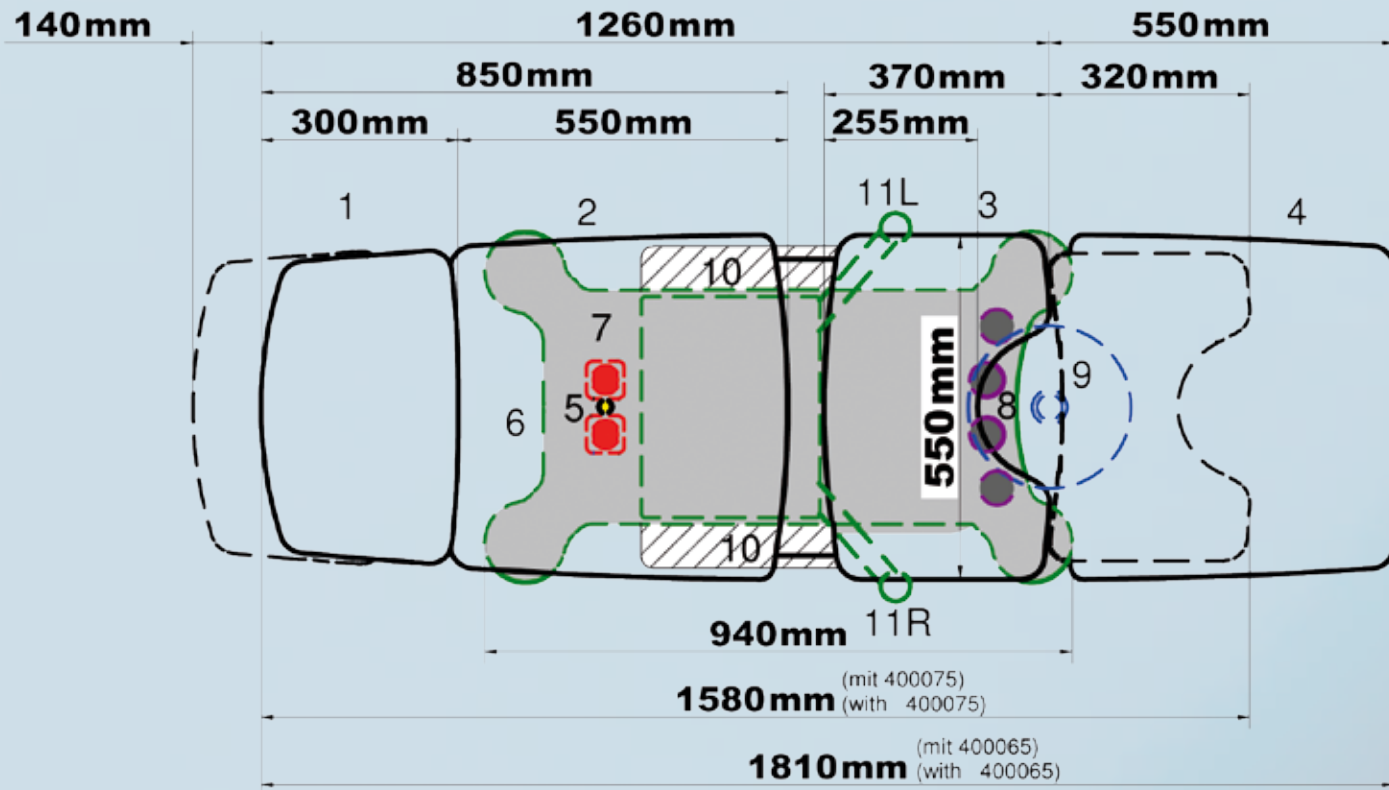

1.	Kopfpolster mit Nackenstütze <i>Head pad with neck rest</i>	7.	Steckdose am Sockel (Zubehör 40675), max. 2 Stück <i>Socket at the base (accessory 40675), max. 2 pieces</i>
2.	Rückenpolster <i>Back pad</i>	8.	Fußschalter <i>Foot switches</i>
3.	Beckenpolster <i>Pelvis pad</i>	9.	Wasserspülung (Zubehör 91705) <i>Rinsing device (accessory 91705)</i>
4.	Beinplatte (Zubehör 400065) <i>Leg plate (accessory 400065)</i>	10.	Anschlussbereich für Wasser außen Ø 1/2", Standard: rechtsseitig <i>External water connection Ø 1/2", standard: right-sided</i>
5.	Potentialausgleich (Zubehör 40676) <i>Potential equalisation (accessory 40676)</i>		Wasserablaufschlauch Ø 40 mm <i>Drainage hose Ø 40 mm</i>
6.	Netzkabelausgang <i>Power cable outlet</i>	11	Kolposkopaufnahme, rechts oder links <i>Colposcope holder, right or left</i>

# UNSER GESAMTPROGRAMM: OUR FULL RANGE OF PRODUCTS:



medifa-hesse GmbH & Co. KG  
Industriestr. 5  
D-57413 Finnentrop

made in Germany



fon +49 2721 7177-0  
fax +49 2721 7177-15

www.medifa.com  
info@medifa.com

Änderungen vorbehalten.

*Data subject to change  
without notice.*

## Impressum

Gesamtherstellung:  
FACT-Werbeagentur  
57368 Lennestadt  
www.fact-werbeagentur.de

© medifa-hesse GmbH & Co.KG

Drucknummer: 4000IV/ED/001-09